



SPnT Coaxial Switches DC to 6 GHz, DC to 20 GHz, DC to 26.5 GHz, DC to 40 GHz

Radiall's PLATINUM SERIES switches are optimised to perform at a high level over an extended life span. With outstanding RF performances, and a guaranteed Insertion Loss repeatability of 0.03 dB over a life span of 10 million switching cycles. PLATINUM SERIES switches are perfect for automated test and measurement equipment, as well as signal monitoring devices.

PART NUMBER SELECTION

R 594 . . 3 . . 7 .

RF Connectors :
3 : SMA up to 6 GHz
4 : SMA up to 20 GHz
F : SMA up to 26.5 GHz
8 : SMA 2.9 up to 40 GHz

Type :
4 : Latching + Self cut-off without indicator
7 : Latching + Self cut-off + Auto Reset + Indicators

Number of Positions :
4 : 4 positions
6 : 6 positions

Options :
1 : Positive common (without TTL) Type "4" or "7"
2 : TTL/5V logic with 24 Vdc supply Type "7" only

Documentation :
- : Certificate Of Conformity
C : Calibration certificate
R : Calibration certificate + RF curves

Actuator Terminal :
7 : HE 10 receptacle, delivered with 750 mm (30 inches) ribbon cable + HE10 connector

PICTURE



**RF PERFORMANCES**

PART NUMBER	R5943-34-7 R5943-36-7	R5944-34-7 R5944-36-7	R594F-34-7 R594F-36-7	R5948-34-7 R5948-36-7
Frequency Range GHz	DC to 6	DC to 20	DC to 26.5	DC to 40
Impedance Ohms	50			
Insertion Loss dB (Maximum)	0.3 + 0.015 x frequency (GHz)			
Isolation dB (Minimum)	100	DC to 6 GHz : 100 6 to 12.4 GHz : 90 12.4 to 20 GHz : 80	DC to 6 GHz : 100 6 to 12.4 GHz : 90 12.4 to 20 GHz : 80 20 to 26.5 GHz : 70	DC to 6 GHz : 100 6 to 12.4 GHz : 90 12.4 to 20 GHz : 80 20 to 26.5 GHz : 70 26.5 to 40 GHz : 60
V.S.W.R. (Maximum)	1.20	DC to 6 GHz : 1.20 6 to 12.4 GHz : 1.35 12.4 to 18 GHz : 1.45 18 to 20 GHz : 1.70	DC to 6 GHz : 1.20 6 to 12.4 GHz : 1.35 12.4 to 18 GHz : 1.45 18 to 26.5 GHz : 1.70	DC to 6 GHz : 1.20 6 to 12.4 GHz : 1.35 12.4 to 18 GHz : 1.45 18 to 26.5 GHz : 1.70 26.5 to 40 GHz : 1.90
Repeatability (measured at 25°C)	0.03 dB			0.05 dB

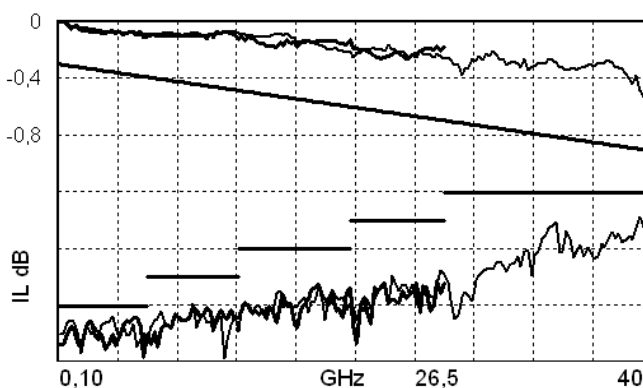
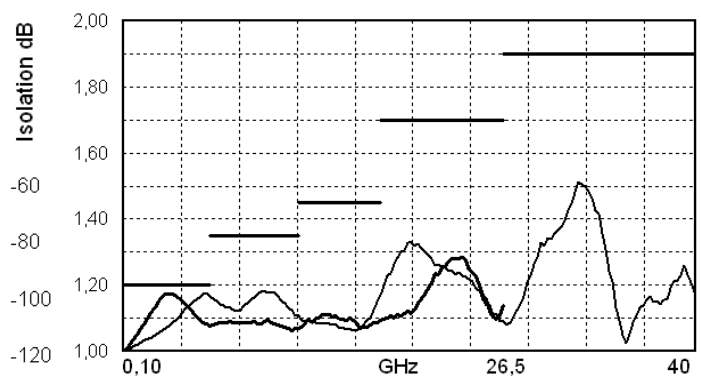
TYPICAL RF PERFORMANCES**Insertion Loss and Isolation****V.S.W.R.**

**ADDITIONAL SPECIFICATIONS**

Operating mode		Latching	
Nominal operating voltage (across operating temperature) Vdc		24 (20 / 32)	
Coil resistance (+/-10%)	Ohms	120	
Nominal operating current at 23°C		200	
Maximum stand-by current		50	
Average power		RF path Cold switching : see Power Rating Chart on page 8 Hot switching : 1 Watt CW	
		Internal terminations 1 Watt average into 50 Ω	
TTL input	High Level	3 to 7 V	1.4 mA max at Vcc = Max
	Low Level	0 to 0.8 V	
Indicator specifications		Maximum withstanding voltage : 60V Maximum current capacity : 150 mA Maximum « ON » resistance : 2.5 Ω Minimum « OFF » resistance : 100 MΩ	
Switching time (max)		15 ms	
Life (min) for	SMA	10 million cycles	
	SMA 2.9	2 million cycles	
Connectors		SMA – SMA 2.9	
Actuator terminal		HE10 ribbon receptacle	
Weight (max)		230 g	

ENVIRONMENTAL SPECIFICATIONS

Operating temperature range	°C	-25 to +75
Storage temperature range	°C	-55 to +85
Temperature cycling (MIL-STD-202 , Method 107D , Cond.A)	°C	-55 to +85 (10 cycles)
Vibration (MIL STD 202 , Method 204D , Cond.D)		10-2000 Hz , 10g operating
Shock (MIL STD 202 , Method 213B , Cond.C)		50g / 6 ms , ½ sine operating
Moisture resistance (MIL STD 202 , Method 106E , Cond.E)		65°C, 95% RH, 10 days
Altitude storage (MIL STD 202 , Method 105C , Cond.B)		50,000 feet (15,240 meters)
RFI (MIL STD 1344 , Method 3008 or IEC 61726)		55dB at 20GHz
Magnetic field		< 5.10 ⁻⁵ gauss at 1 meter



ELECTRONIC POSITION INDICATORS

This option is not available with type 4.

The electronic position indicators utilise photo-MOS transistors which are driven by the mechanical position of the RF paths moving elements. The circuitry consists of a common which can be connected to an output corresponding to selected RF path. If one or several RF paths are closed, the corresponding indicators are connected to the common. The photo-MOS transistors are configured for AC and/or DC operation. The electronic position indicators require the supply (20 to 32 VDC) to be connected to pin 1 and ground connected to pin 15.

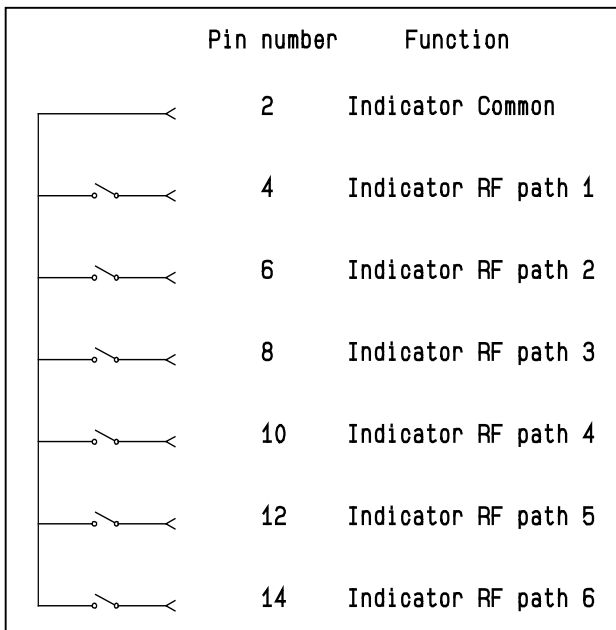

Ways 1 and 4 are not connected for SP4T switches.



DRIVING THE SWITCH

Type 4 : without TTL and without indicator.

Each RF path is driven independently. Each path can be closed or open by applying ground to the corresponding "open" or "close" pin.

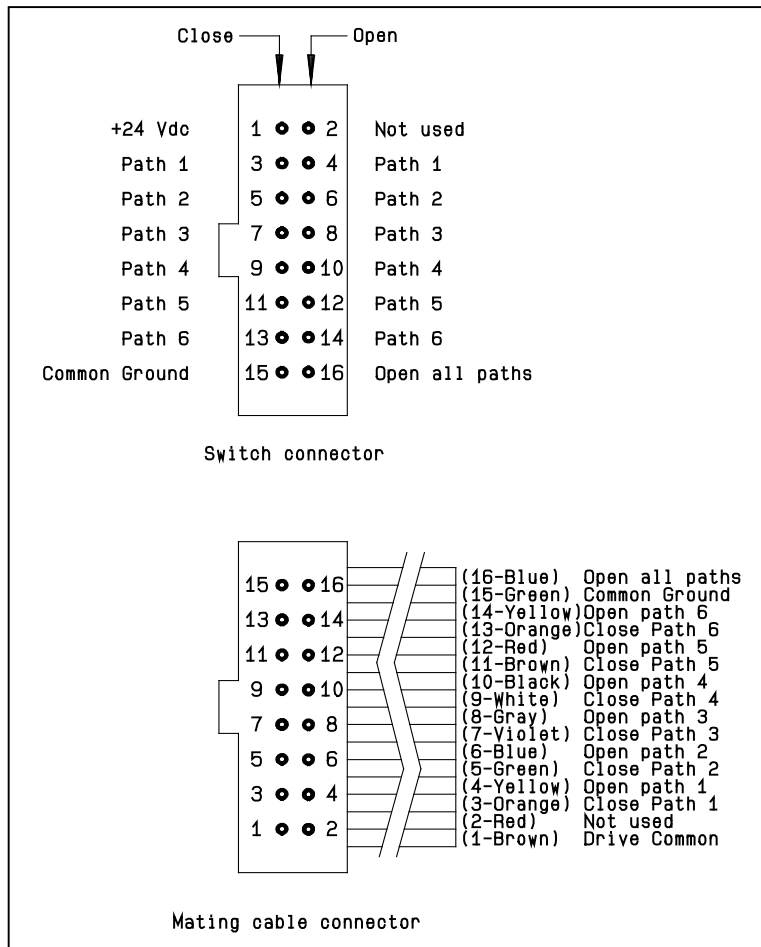

Standard drive:

- Connect pin 15 to ground.
- Connect pin 1 to supply (+20 VDC to +32 VDC).
- Select desired RF path by applying ground to the corresponding "close" pin (Ex: ground pin 3 to close RF path 1).
- To open desired RF path connect ground to the corresponding "open" pin (Ex: ground pin 4 to open RF path 1).
- To open all RF paths, first ensure that all RF path "close" pins are disconnected from ground. To complete the operation, connect pin 16 to ground.

Make-Before-Break

Make-Before-Break switching can be accomplished by closing the new RF path before opening the previously selected RF path. To complete the operation, close the new RF port. A minimum of 15 ms must be allowed before opening the previously selected RF port.

Ways and 4 are not connected for SP4T switches.



Type 7 : with TTL (option "2") / without TTL (option "1") and indicators.

Each RF path can be closed by applying Ground or TTL "High" for option 2 to the corresponding "drive" pin. In general, except for Make-Before-Break drive, all other RF paths are simultaneously opened by internal logic.

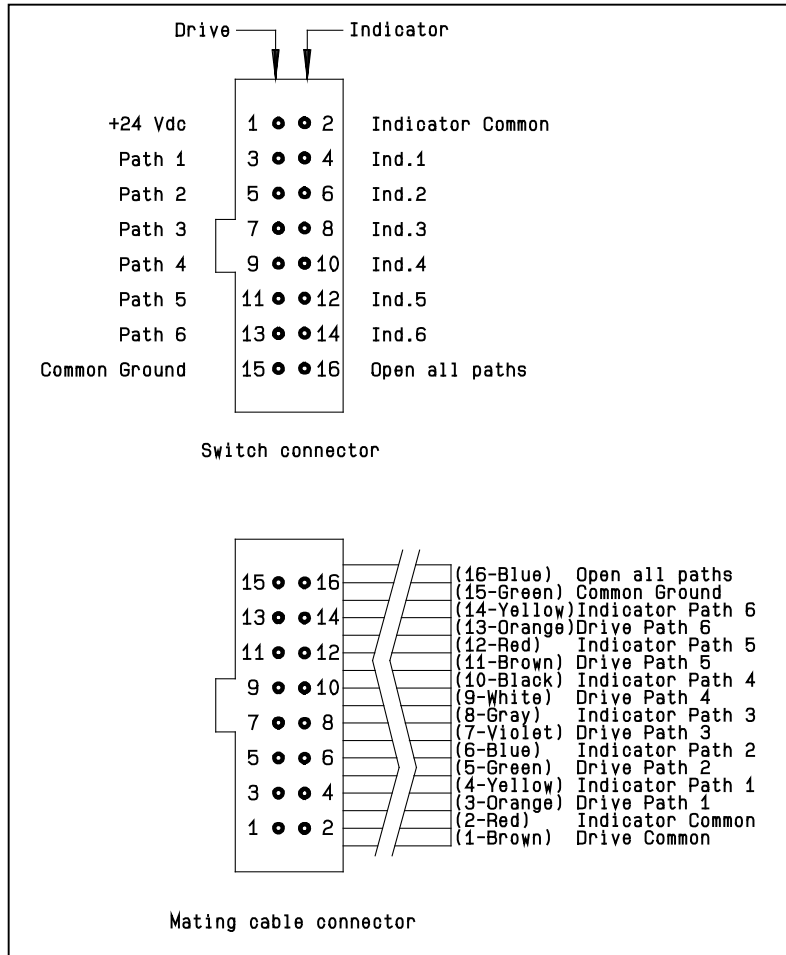

Standard drive option "1"

- Connect pin 15 to ground.
- Connect pin 1 to supply (+20 VDC to +32 VDC)
- Select (close) desired RF path by applying Ground to the corresponding "drive" pin (Ex: apply Ground to pin 3 to close RF path 1).
- To select another path, ensure that all unwanted RF path "drive" pins are disconnected from Ground (to prevent multiple RF path engagement). Apply Ground to the "drive" pin which corresponds to the desired RF path.
- To open all RF paths, ensure that all RF path "drive" pins are disconnected from Ground. Complete the operation by applying Ground to pin 16.

TTL drive option "2"

- Connect pin 15 to ground.
- Connect pin 1 to supply (+20 VDC to +32 VDC)
- Select (close) desired RF path by applying TTL "High" to the corresponding "drive" pin (Ex: apply TTL "High" to pin 3 to close RF path 1).
- To select another path, ensure that all unwanted RF path "drive" pins are in TTL "Low" position (to prevent multiple RF path engagement). Apply TTL "High" to the "drive" pin which corresponds to the desired RF path.
- To open all RF paths, ensure that all RF path "drive" pins are in TTL "Low" position. Complete the operation by applying TTL "High" to pin 16.

Break-Before-Make

Open the undesired RF path. After 15 ms (minimum), close the new RF port.

Make-Before-Break

Ensure that the previously selected RF path "drive" is connected to Ground (or TTL "High" for option "2", then close the new RF path.

Ways 1 and 4 are not connected for SP4T switches.



TYPICAL OUTLINE DRAWING

SMA connectors

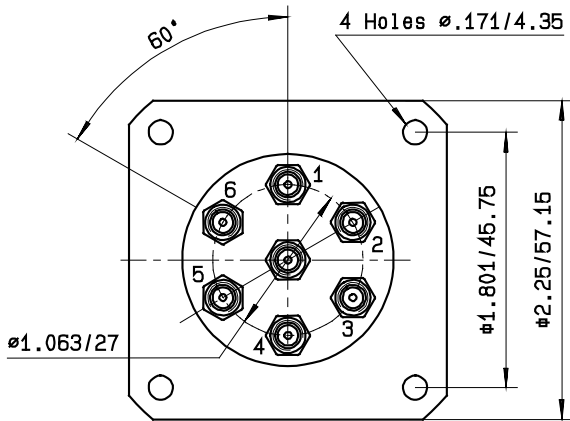

SMA 2.9 connectors

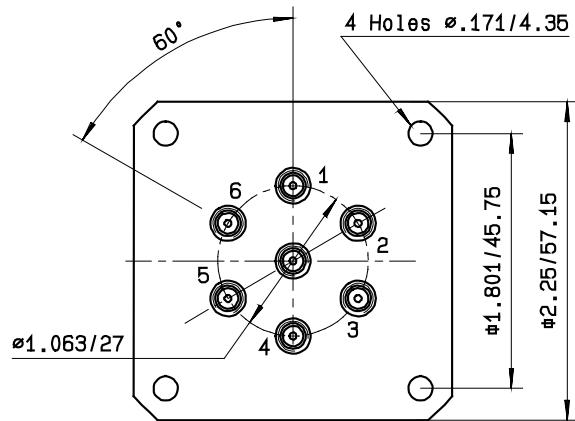

16 pin HB10 male connector

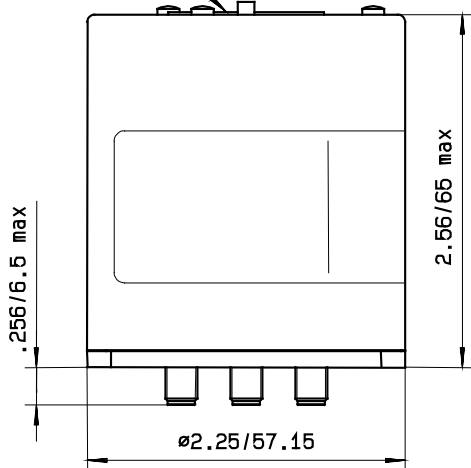

16 pin HB10 male connector

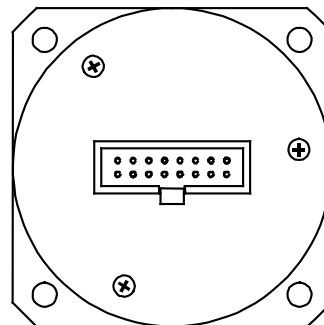
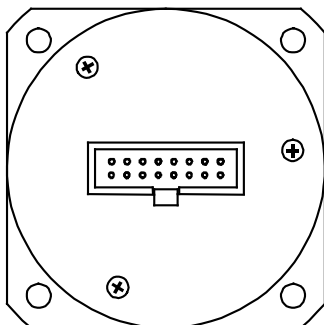
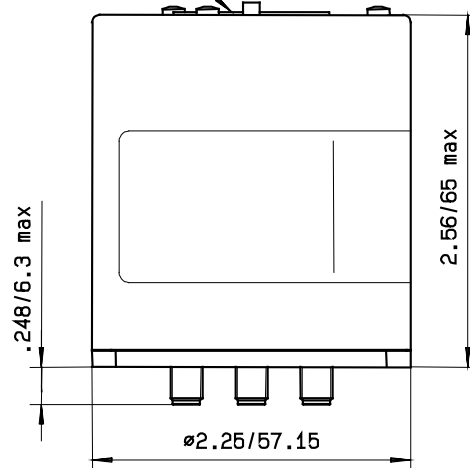

All dimensions are in inches/millimetres.

Ways 1 and 4 are not connected for SP4T



POWER RATING CHART

This graph is based on the following conditions :

- Ambient temperature : + 25°C
- Sea level
- V.S.W.R. : 1 and cold switching

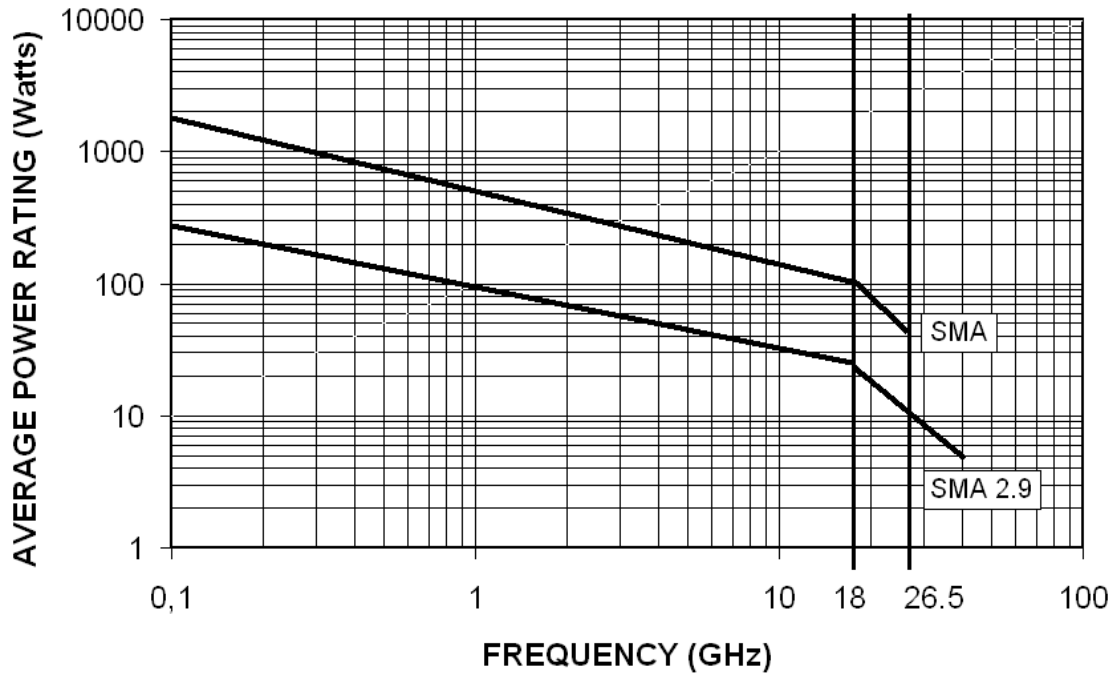

DERATING FACTOR VERSUS V.S.W.R.

The average power input must be reduced for load V.S.W.R. above 1.

